



Installation Manual

Aluminium loading ramps

Issue: 05.2023 ver.01

Language

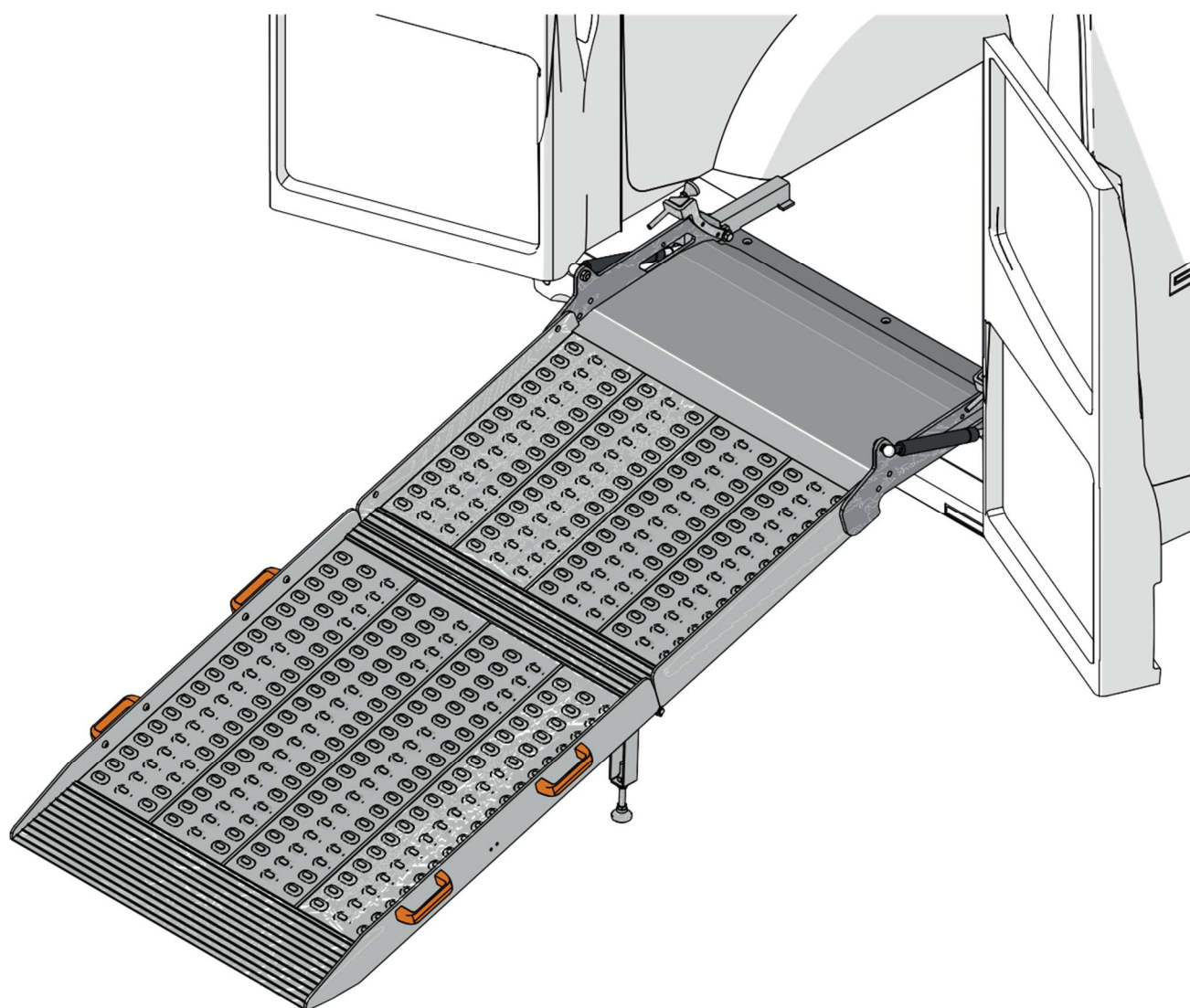

T.R.I. THE RAMP ITALY SRL

Via 11 Settembre 5/E - 43058 Sorbolo Mezzani (PR) - Italy

Tel. + 39 0522 820241

www.therampitalysrl.com

Index

- 1 : GENERAL INFORMATIONen-3**
 - 1.1 About the manual.....en-3
 - 1.1.1 General information.....en-3
 - 1.1.2 Manufacturer’s Contact Detailsen-3
 - 1.1.3 Customer serviceen-3
 - 1.1.4 Introduction and Safety Informationen-4
 - 1.1.5 Product Detailsen-5
 - 1.1.6 Guaranteeen-6

- 2 : INSTALLATIONen-9**
 - 2.1 Safety warnings.....en-9
 - 2.2 Packingen-9
 - 2.3 Optional accessoriesen-10
 - 2.4 Getting Started.....en-11
 - 2.5 Fitting the ramp with a fixed and revolving baseen-11
 - 2.1 Fitting the quick-release couplings (optional)en-17
 - 2.2 The revolving ramp baseen-21

1 : GENERAL INFORMATION

1.1 About the manual

1.1.1 General information

The Ramp Italy designs, manufactures and distributes loading ramps for vans. Its recently developed product range offers a tangible solution for professionals handling heavy loads day after day, or as mobility aids for people with disabilities. Our intention is to continue expanding our range in the near future so we can offer products whose increasingly technological design represents added value for the work carried out by our customers and has the ability to enhance the quality of life of other people. The strength of our company comes from the combination of the **meticulous engineering of each individual mechanical part and the rigorous selection of raw materials**. The entire manufacturing cycle, from the raw materials to the finished product, takes place in Italy because this is the only way can offer the guarantee and adequate control of our quality standards with confidence.

Please read and follow these installation instructions with care so you are sure the loading ramp is fitted correctly onto your vehicle.

The manufacturer is not liable for injury or damage resulting from the incorrect or improper use of the loading ramp

The manufacturer reserves the right to make any modifications to the various models in order to comply with current technical standards.

Contact your dealer's customer service team in case of complaint.

1.1.2 Manufacturer's Contact Details

Manufacturer:	T.R.I. THE RAMP ITALY SRL
Address (registered premises):	Via 11 Settembre 5/E - 43058 Sorbolo Mezzani (PR) - Italy
Telephone:	+ 39 0522 820241
E-mail	info@therampitalysrl.com
Website	www.therampitalysrl.com

1.1.3 Customer Service

Contact your dealer's customer service point for any technical queries. Make a note of your product's name before calling customer service.

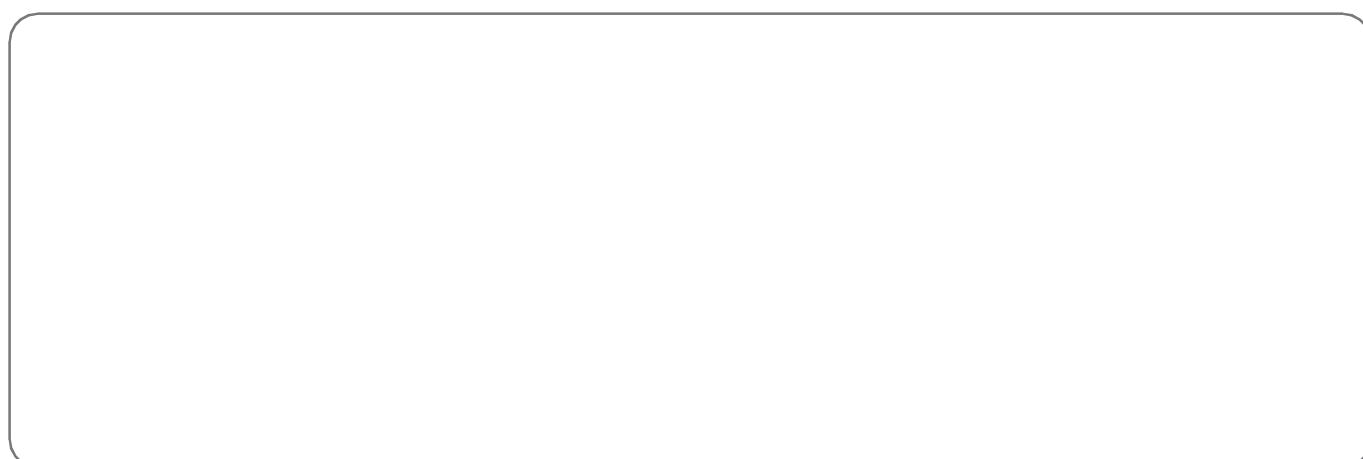

Fig. 1.1

DEALER'S STAMP AND CONTACT DETAILS OF THE AUTHORISED CUSTOMER SERVICE POINT

1.1.4 Introduction and Safety





Being careful and cautious when installing the loading ramp is the best way to prevent accidents.

Comply with the information provided on the name plates and any labels attached to the device. Damaged name plates/labels should be replaced immediately.

Any work to the machine for any other reason than its intended use may only be carried out by qualified professionals.

Keep this document in a safe place so you can refer to it at any time. Remember to give it to the new owner in case of sale or transfer.

Please read the safety messages provided in the introduction to this manual and the safety markings: "Attention", "Warning" and "Danger" in the text.

	<p>This symbol means: NOTE</p> <p>This symbol is used to bring your attention to handy tips, correct procedures and conduct. If you follow the instructions marked by this symbol, you will encounter fewer issues.</p> <p>The symbol is used to bring your attention to special methods or procedures you should follow to safeguard the correct use of the product.</p>
	<p>This symbol means: WARNING</p> <p>This symbol is used to bring your attention to safety information. Failure to follow these instructions may result in minor injury or damage to the equipment.</p>
	<p>This symbol means: ATTENTION</p> <p>This symbol is used to bring your attention to safety information. Read it carefully. Failure to follow these instructions may result in death, serious injury or damage to equipment.</p>
	<p>This symbol means: DANGER</p> <p>This symbol is used to bring your attention to a hazardous situation for yourself or others. Read it carefully. Failure to follow these instructions may result in serious injury or death.</p>

1.1.5 Device identification

Name plate

The name plate contains the following information:

- A - Manufacturer
- B - Manufacturer's details
- C - Device type
- D - Serial number
- E - Year of manufacture
- F - Loading Capacity
- G - CE mark

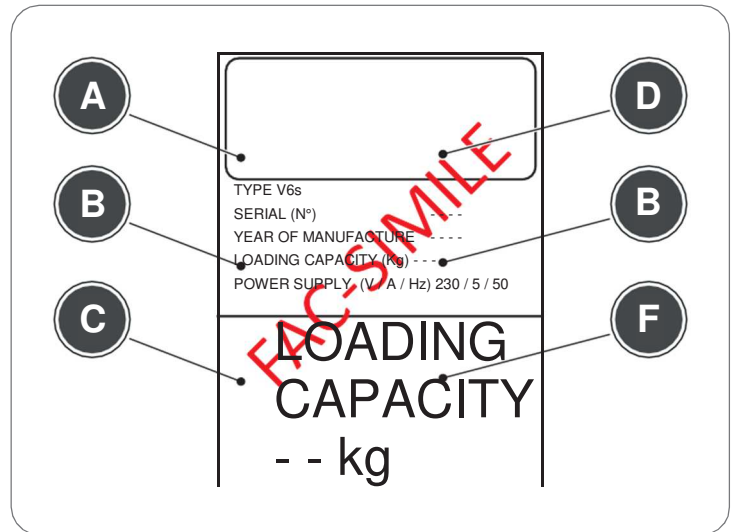

Fig. 1.2



NOTE: Take a note of the product's name and serial numbers so you have the information to hand in case of need.



NOTE: Remember that providing the information on the name plate will ensure you have the best customer service experience and be supplied the correct spare parts.

Location of the name plate

The product's name plate is located at the side.

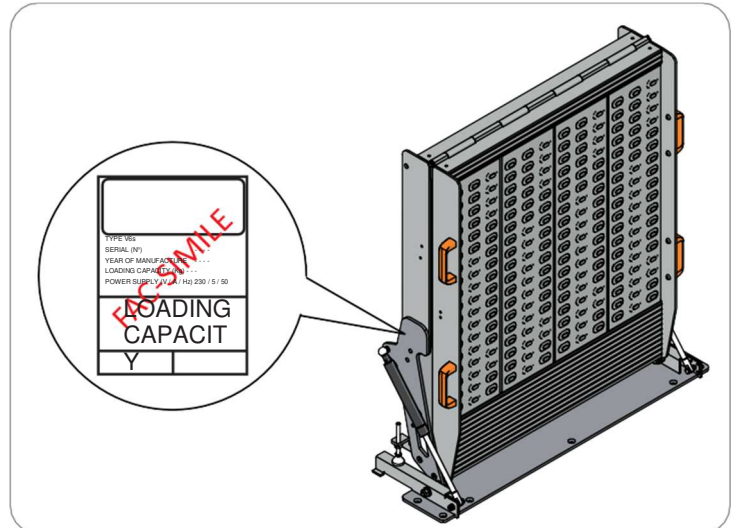

Fig. 1.3

EC Declaration of Conformity

The manufacturer of the products described in this manual and referred to in this declaration, declares under sole responsibility that these products comply with the basic safety, health and protection requirements of the relevant EC directives, and that the associated test reports, in particular the EC declaration of conformity duly issued by the manufacturer or his authorised representative, are available for inspection by the competent authorities and on request made to the dealer who sold the equipment.

1.1.6 Guarantee

GENERAL TERMS AND CONDITIONS OF SALE

By returning the ORDER CONFIRMATION online or by email by way of approval, the customer implicitly confirms they are familiar and unconditionally agree with our general terms and conditions of sale and that they will fulfil all the associated obligations with regard to the manufacturer. The manufacturer may implement any amendments or additions to these general terms and conditions of sale at any time, also in order to comply with changes to the law, without notice.

ORDERS

After receiving an order from the customer, the manufacturer will send an ORDER CONFIRMATION by e-mail containing all the relevant information for the order. The order will only be considered as final and accepted after the manufacturer has received the payment as agreed in addition to the ORDER CONFIRMATION by email providing any other information required for the issue of the sales invoice and the correct delivery of the goods. The customer is liable for any additional transport costs incurred as a result of insufficient information being provided.

PRICES

Prices are determined when the offer is formalised and/or the order confirmation is sent. Should it be impossible to determine the price, the customer agrees to the price of the product defined after work has been completed and the final cost of the product or service provided can be calculated.

FINISHES

The colours, coatings and finishes illustrated on our website are by way of example because it is not technically possible to guarantee they are a perfect representation of the original colours. This does not constitute grounds for complaint.

DELIVERY

Delivery times are approximate. The manufacturer is not liable for early or late delivery, and cannot be held responsible for the relative causes. Goods will be delivered to the destination as indicated by the customer on the FINAL ORDER CONFIRMATION. Products are packed appropriately for shipment. Goods returned in packing which was not originally provided by the manufacturer will not be accepted, if this was specifically requested. Prior notification is required for individual or specific packing. The manufacturer reserves the right to modify the packing.

TRANSPORT

Transport is not normally included in the offer or order confirmation, unless specified otherwise. When previously agreed, the goods will be delivered to the destination confirmed by the customer and indicated on the "ORDER CONFIRMATION" by a national or international courier, in appropriate packing, accompanied by transport documents or a shipping invoice. The associated cost will be specified at the time of the order and appear on the order confirmation or quotation. The customer and/or the chosen carrier will be liable for any damage caused to goods during transport. The manufacturer is not liable for any damage caused during transport when the terms are EX WORKS. Should the customer prefer to use his own carrier for transport, which therefore accepts the associated charges in the invoice, all information must be provided to ensure correct packing and handling in addition to the actual transport of the requested product.

PAYMENTS

The payment terms are determined when the offer is formalised and are stated in the order confirmation. Different terms of payment must be notified before an order is placed and always at least 5 (days) from reception of the order confirmation. The manufacturer reserves the right to accept or refuse the proposed new terms. If both parties agree to defer payment, payment must be made by bank transfer within 30 days of the invoice date, unless agreed otherwise. Payment is considered as completed when the amount is made available to the manufacturer by his bank in Italy. Should the parties agree to payment in advance without further specification, said payment refers to the price in full. The customer is liable for any bank charges or fees associated with the payment, unless agreed otherwise.

DELIVERY TERMS

Unless agreed otherwise in writing, delivery dates are not binding for the manufacturer. Unless the parties agree otherwise, the approximate delivery period is specified in the order confirmation. The manufacturer reserves the right to send partial deliveries, within reason. Any liability for delivery resulting from force majeure or other unforeseeable events not caused by the manufacturer including, but not limited to: strikes, lock-outs, government regulations, subsequent blocks on the export or import of goods, with regard to their duration and extent, release the manufacturer from any obligation to comply with agreed delivery dates. The manufacturer is under no obligation to accept the return of products unless this was agreed in writing. The customer is liable for any costs associated with returns.

DELIVERY OF GOODS - CONTROL

When taking delivery of goods, the customer must check the following before signing off the delivery note, which the courier will require the customer to sign:

- the number of packages delivered matches the number indicated on the delivery note. In case of any discrepancy, the customer may still accept the delivery of the goods but must write clearly the total number of packages actually received on the delivery note. The customer must inform the manufacturer of any discrepancy immediately by e-mail (info@therampitalysrl.com).
- the packing is intact (i.e. not wet, punctured, damaged or otherwise) and the packing tape is intact.

Should the customer note any obvious damage or tampering to the packing, they should clearly write "GOODS ACCEPTED WITH RESERVE DUE TO DAMAGED PACKING" on the delivery note, and notify the manufacturer immediately by e-mail. In the event of evident damage to incoming goods, the customer may refuse to take delivery provided the reason for said refusal is stated clearly on the delivery note, and the manufacturer is notified immediately by e-mail.

For greater protection against the possibility of hidden damage caused during transport, we recommend clearly writing "DELIVERY SUBJECT TO VERIFICATION OF GOODS" on the delivery note, even if there is no obvious damage to the packing. If any hidden damage is subsequently found, the manufacturer must be notified by registered letter with return receipt within 15 days of taking reception of the goods.



ATTENTION: If the customer accepts the goods and signs the consignment note without writing the above reserve comments on the delivery note, it will no longer be possible to submit a claim for missing or damaged items, because signing the delivery note implies you have checked and accept the conformity

UNCOLLECTED GOODS

In case of failure to deliver goods, the goods will remain available for the customer in storage for a maximum of five calendar days. After this, they will be sent back to the sender. Under no circumstances can the manufacturer be considered liable for costs incurred for the storage of the goods or for their return. Said charges remain the responsibility of the customer. For this reason, the customer must specify all information required by the manufacturer on the PURCHASE ORDER in order to avoid unnecessary increases in costs.

RIGHT TO REPLACEMENT IN CASE OF DAMAGE DURING TRANSPORT

In order to exercise said right, the customer must send an e-mail to: info@therampitalysrl.com within 15 (fifteen) days of taking receipt of the goods, indicating the number of the transport document or shipping invoice, product code and the number of faulty items complete with details of the fault found. The manufacturer may require the customer to send an e-mail with digital photos showing the damage found. After ascertaining the extent of the damage, the manufacturer will inform the customer by e-mail if he accepts the replacement complete with the details for collection by the courier. The goods must be returned to the manufacturer in their carefully-sealed, original packing, writing the return address on the packing according to the instructions provided. The manufacturer may refuse to take collection of the returned goods and not replace the material in case of failure to comply with the above instructions. The manufacturer is liable for payment of transport costs incurred for said replacement, whether for the return of damaged goods or for replacement. Goods will be replaced as quickly as possible. The return of goods for cash-on-delivery will not be accepted under any circumstances. Notifications received after the above deadline will not be taken into consideration.

CONSUMER GUARANTEE

Products are guaranteed against faults for 24 months after delivery. The manufacturer is unable to guarantee the products comply with given features or technical specifications, or are suitable for specific uses, unless said features were specifically noted in the contract or in documents that the contract or purchase order refer to. The guarantee only applies to products used in an environment and for applications that are consistent with the specifications declared by the manufacturer. Any improper use is prohibited. The guarantee is not valid if the fault or anomaly is the result of the incorrect or unsuitable application of the product, or is not compliant with commissioning. Any unauthorised modification or replacement of product parts will invalidate the guarantee and release the manufacturer from any civil or criminal liability. The guarantee does not cover the normal wear and tear of parts.

The manufacturer guarantees that the item sold conforms to specifications as stated and is suitable for the intended use of the product. The customer must report any faults or anomalies in the delivered product within 30 days of discovering said defect, under penalty of forfeiture. The right to claim is forfeited six months after discovery. The period allowed for reporting apparent anomalies and/or faults in the goods begins on the delivery date of the goods. The guarantee will be invalidated in case of damage resulting from abnormal use of the product by the customer or due to environmental conditions including, but not limited to: excessive humidity in the room, overheating of the room, exceptional, excessive or abnormal temperatures and climate conditions, or improper use including incorrect maintenance (cleaning without using the proper products or tools), or any other use than the intended use of the product. In order to exercise this right, the customer must document the fault or anomaly found and send this information by registered letter with return receipt to The Ramp Italy srl, 43058 - Via 11 Settembre 5/E Sorbolo Mezzani (PR), within the above terms and also send, if so requested, an e-mail including any digital photos, or make arrangements to return the faulty item, if necessary and requested by the manufacturer. This will enable the manufacturer to ascertain whether the fault is the result of production problems (conformity defects). In this case, the faulty material will either be repaired or replaced provided the faulty item is returned. The item will not be replaced free of charge should the manufacturer determine improper use of the product by the customer. After receiving said notification and/or documentation, the manufacturer will notify his decision within 15 working days and also authorise or refuse authorisation for the return of the faulty material. At the same time, he may send a document by e-mail to be attached to the goods to be returned. The material must be sent to the address as indicated. The replacement will be handled as promptly as possible. The manufacturer is liable for the transport costs incurred for said replacement, whether for the return of goods or for the replacement.

RIGHT OF WITHDRAWAL

If the CUSTOMER intends to dispute the compliance of any of the items delivered, he must notify this in writing, as described in the paragraph "DELIVERY OF GOODS - CONTROL". Items shall be considered as accepted in full in case of failure to comply with this requirement.

HANDLING OF PERSONAL INFORMATION

The personal details of the customer will be handled according to Italian law relating to the handling of personal information (Legislative Decree 196/2003). The manufacturer hereby informs the customer that he is the data controller and that the customer's personal details will only be collected and handled in order to execute the terms of this agreement. Pursuant to Article 7 of Legislative Decree 196/2003, the customer has the right to request that the manufacturer updates, rectifies, supplements, deletes or transforms their personal details into an anonymous format.

APPLICABLE LAW

For any other issue not expressly agreed by the parties, the provisions of Italian law and the regulations in the Italian Civil Code and Legislative Decree 205/06 (Consumer Code) shall apply.

COURT of JURISDICTION

The parties expressly agree that any dispute relating to the interpretation and execution of the terms of purchase will be under the exclusive jurisdiction of the Court of Reggio Emilia.

PAINT

Our standard colours are RAL 9006 for the ramp. They may have a smooth or textured finish. We use polyester paints for outdoor use (50-80 microns). Not suitable for special applications, including: marine environments or environments close to the sea, sandy environments, chemical environments, other types of environment.

PACKING

Packing is included in the price and is used to ensure the goods are not damaged during transport. If packing looks damaged, this must be reported before the transport documents are signed.

CLEANING AND MAINTENANCE

The customer is responsible for cleaning and maintaining the ramp. Check the ramp bolts on a routine basis. Inspect the ramp and remove any dirt.

RESPONSIBILITY

T.R.I. is not liable in case of failure to undertake maintenance, installation in any other environments than those indicated or if not specified, modifications without written authorisation, penalties for delays or work carried out without our consent. The guarantee is valid for 24 months. Failure to report damage incurred during transport or to report any malfunction within the allocated time frame will not be considered. For any other information, refer to the technical drawings or data sheets of the individual products.

2 : INSTALLATION

2.1 Safety Warnings

	DANGER Keep children (and any persons with a physical, sensory or mental impairment) at a safe distance from the product during all stages of installation.
	ATTENTION: Use of the ramp by persons who are not self-sufficient, with a sensory or mental impairment is only permitted provided they are under the supervision of persons responsible for their
	ATTENTION: Inform customer service in case of ramp malfunction. Never attempt to repair the ramp yourself.
	ATTENTION: All repair work must be carried out by qualified personnel.
	WARNING Check the ramp is intact after removing it from its packing. Contact the manufacturer immediately and before carrying out any assembly work if the product is damaged.
	NOTE: Read the instructions carefully before installing the ramp. The manufacturer is not liable for any damage or malfunction caused by incorrect installation or failure to follow the instructions provided in this manual.
	NOTE: T.R.I. The Ramp Italy reserves the right to modify/update the Installation Manual without notice.

2.2 Packing

Example of ramp packing (*).

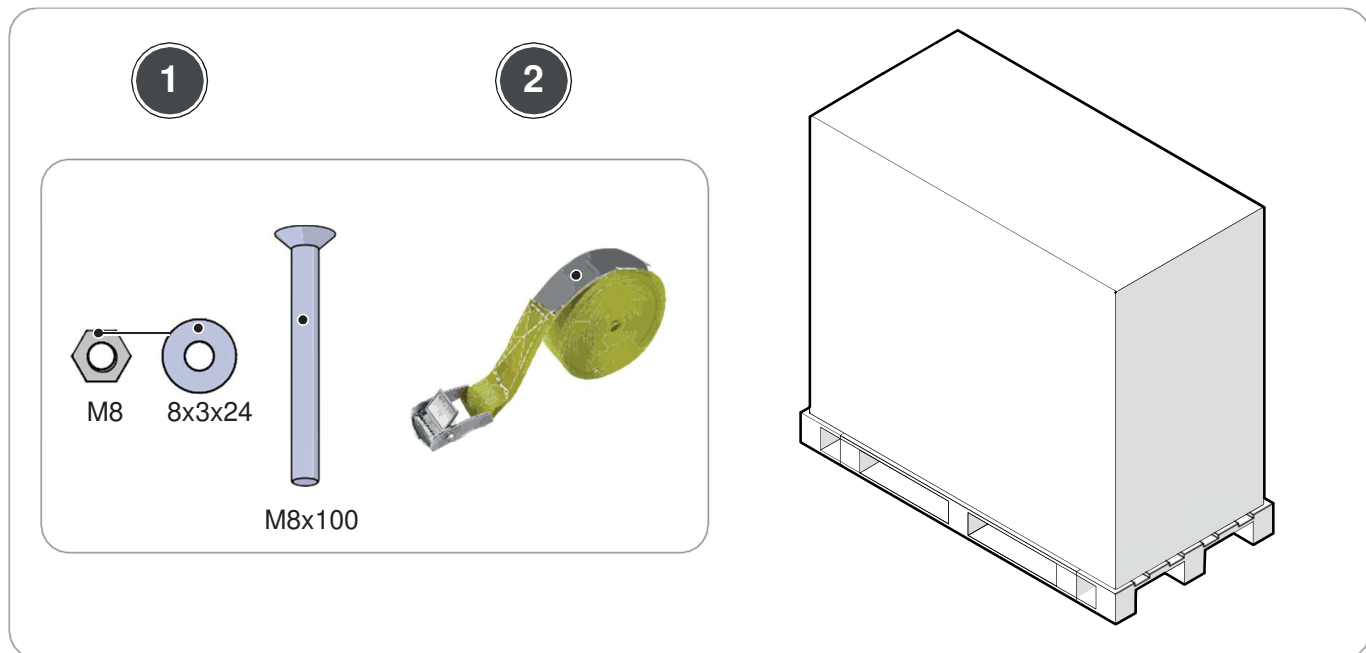

Fig. 2.1

Supplied as standard:

- 1) - **Installation kit** (M8x100 galvanised countersunk head screws, M8 self-locking nuts, and 8x3x24 galvanised washers)
- 2) - **Safety strap to secure the load**

	NOTE: (*) Pallet dimensions vary depending on the size of the ramp.
--	--

2.3 Accessories available on request

Quick-release coupling

The quick-release coupling is a useful accessory for anyone who has to take the ramp off their vehicle on a regular basis. The system is fitted with catches that are screwed down and locked in place with handles.

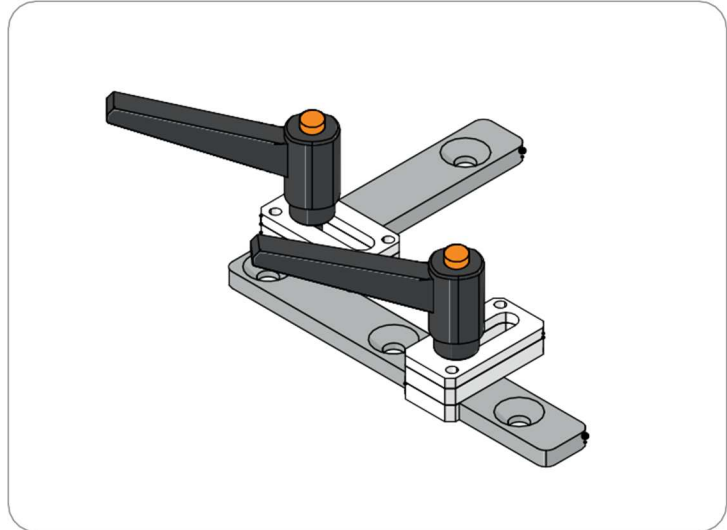

Fig. 2.2

Revolving base

The optional revolving base is designed to facilitate the loading of goods that do not require the use of a ramp. The ramp can be opened like a door, inwards or outwards, leaving the cargo area free.

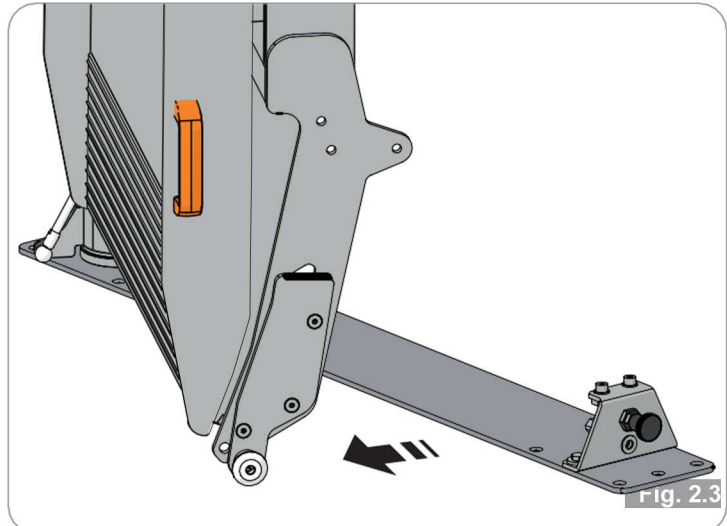

Fig. 2.3

Second locking device for the revolving base

This safety device is used to lock the revolving ramp in place.

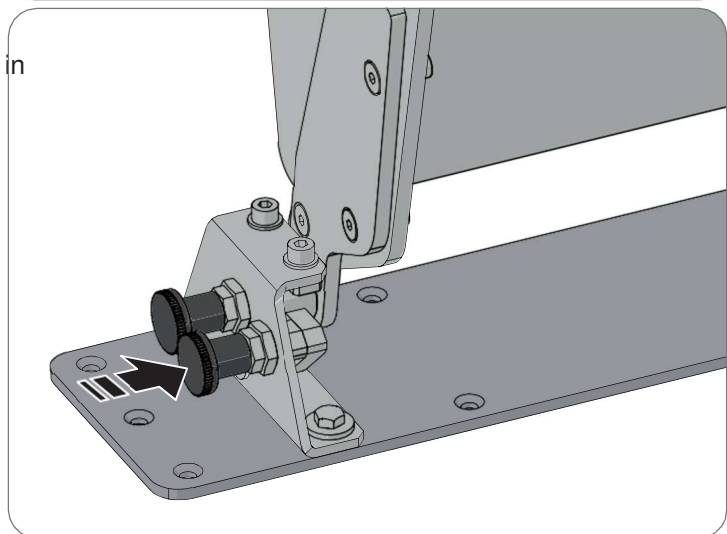

Fig. 2.4

2.4 Preliminary Operations



ATTENTION: Make sure you comply with all regulations and safety standards during installation.
Wear protective safety footwear.
Wear sturdy work gloves.



WARNING Check the cargo area of the van is level and there are no obstacles inside the area where the ramp will be fitted.



WARNING After removing the packing material, check that the safety labels are in place. Contact customer service if they are damaged or deteriorated.

2.5 Fitting the ramp with a fixed or revolving base



NOTE: The illustrations below refer to ramps with either a fixed base or a revolving base.

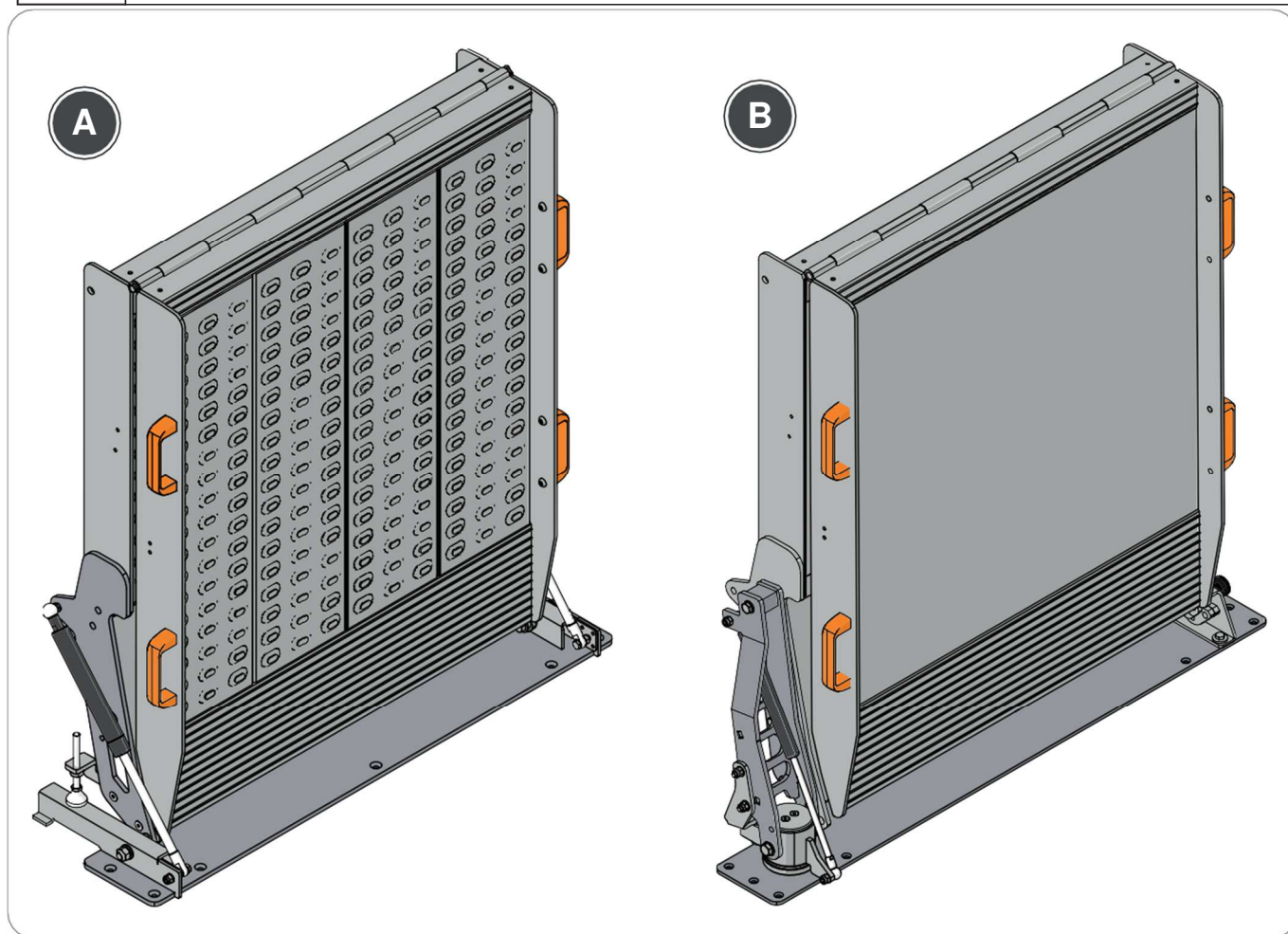

Fig. 2.5

A) - Fixed base ramp

B) - Revolving base ramp



ATTENTION: Two people are required to carry out the following step. Take care: the ramp is very heavy!

Lift up the ramp and put it onto the surface of the van's cargo area.

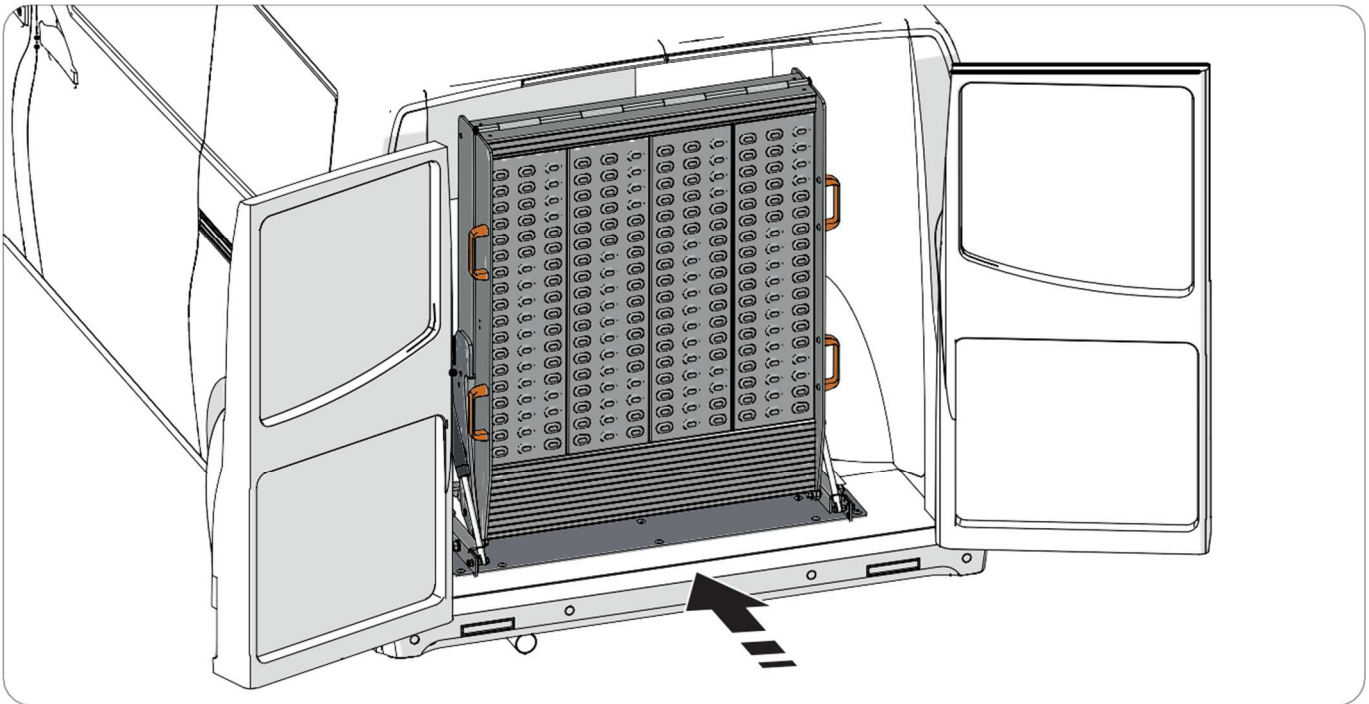

Fig. 2.6

Align the ramp's baseplate correctly up with the cargo area. The baseplate must sit parallel to the surface of the cargo area (use the end of the van's body or the bumper as a reference).

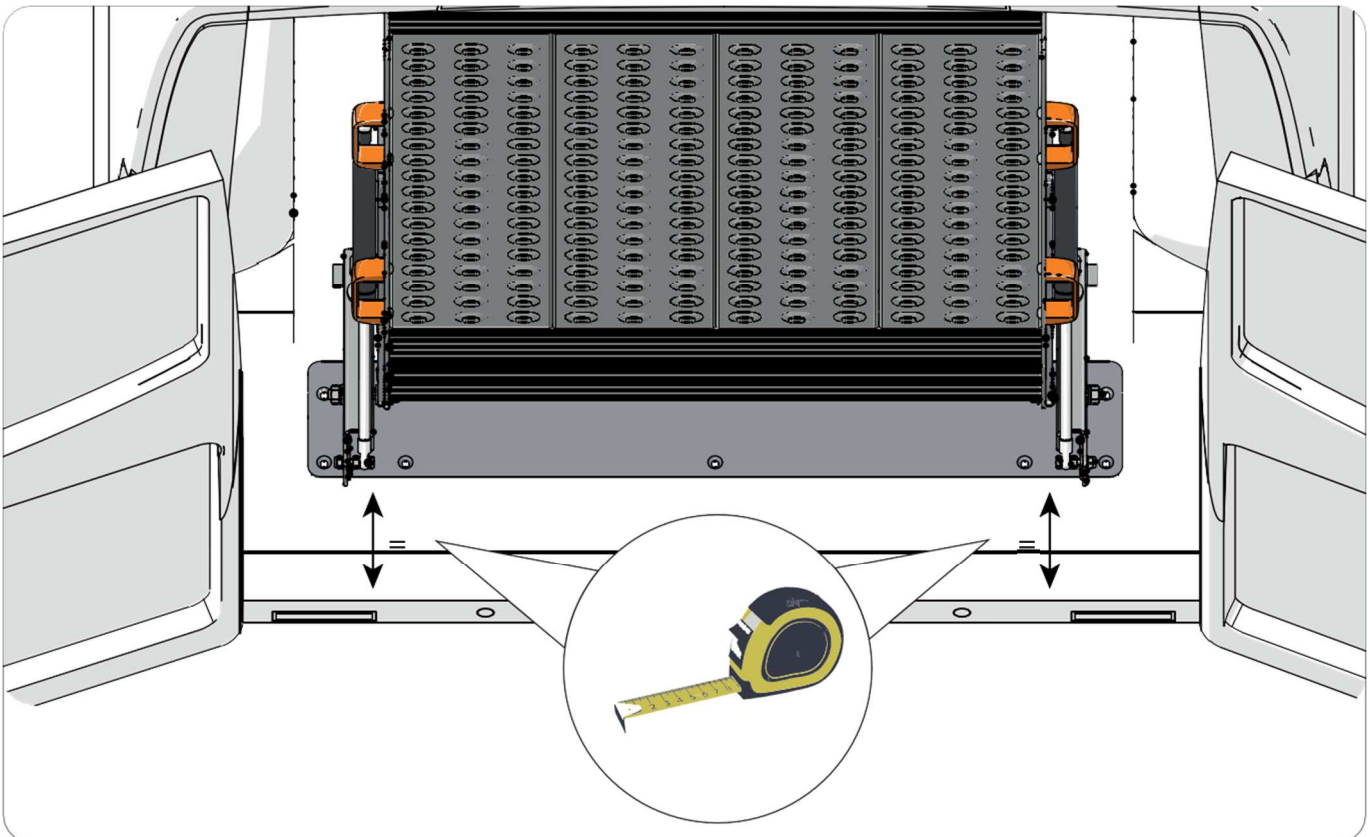

Fig. 2.7

Check the van doors still close properly.

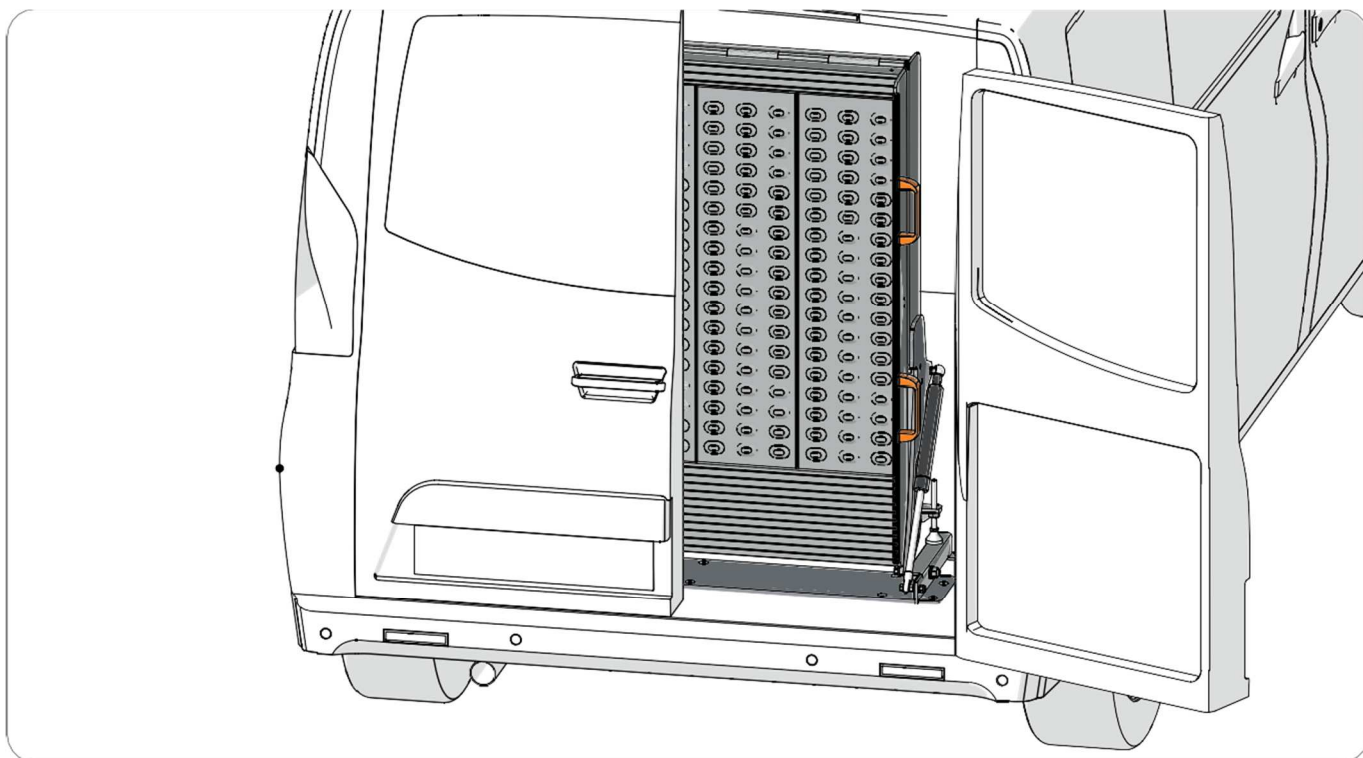

Fig. 2.8



WARNING Check there are no obstacles on the underside of the van before drilling into it. Pay particular attention if there is any electrical wiring.

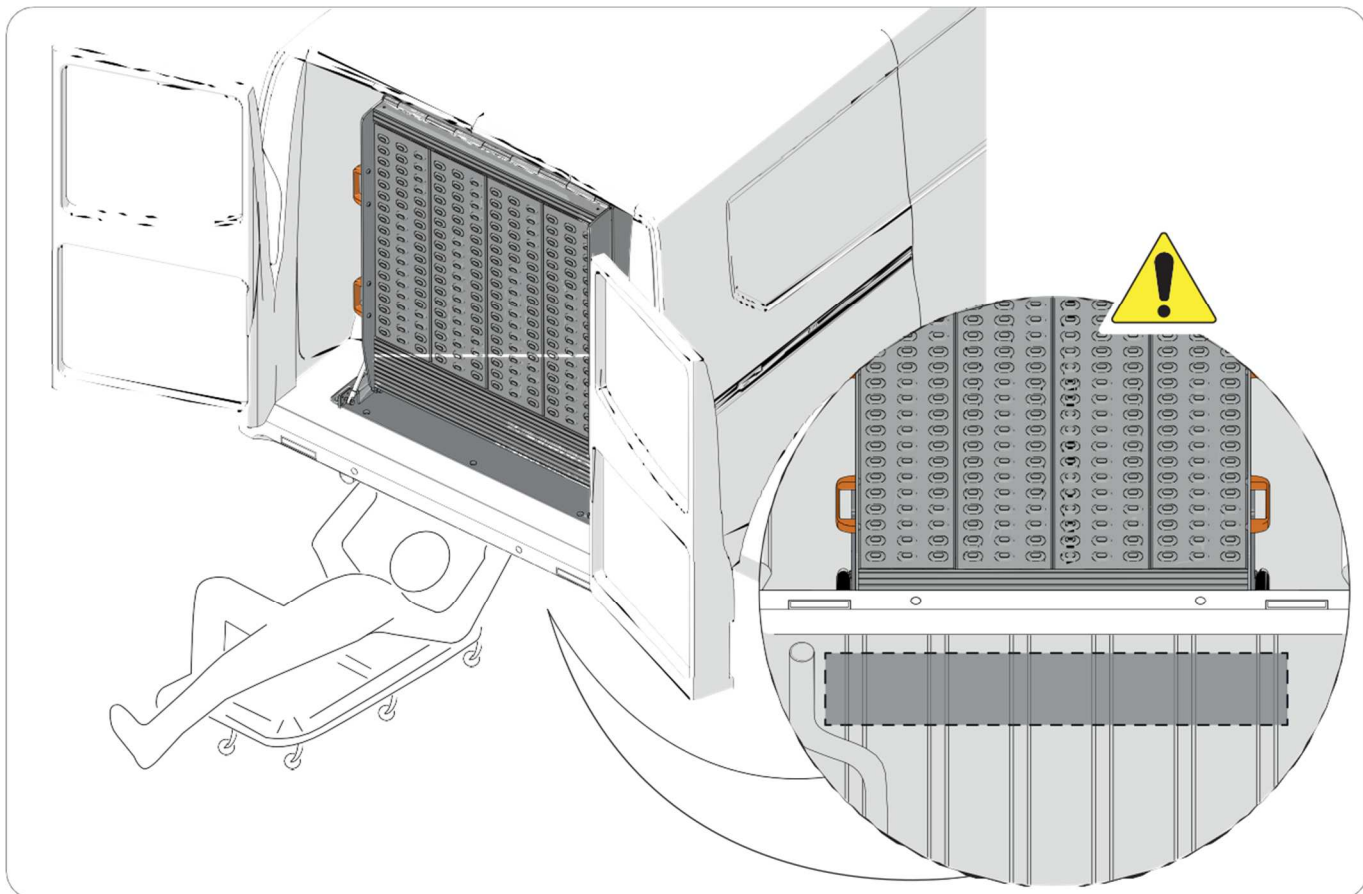

Fig. 2.9

Mark all holes to be drilled in the ramp's baseplate using a felt-tip pen.



NOTE: We also recommend marking the contours/edges of the ramp's baseplate as this will make it easier to line it up.

A) - Baseplate for fixed base ramp

B) - Baseplate for revolving base ramp

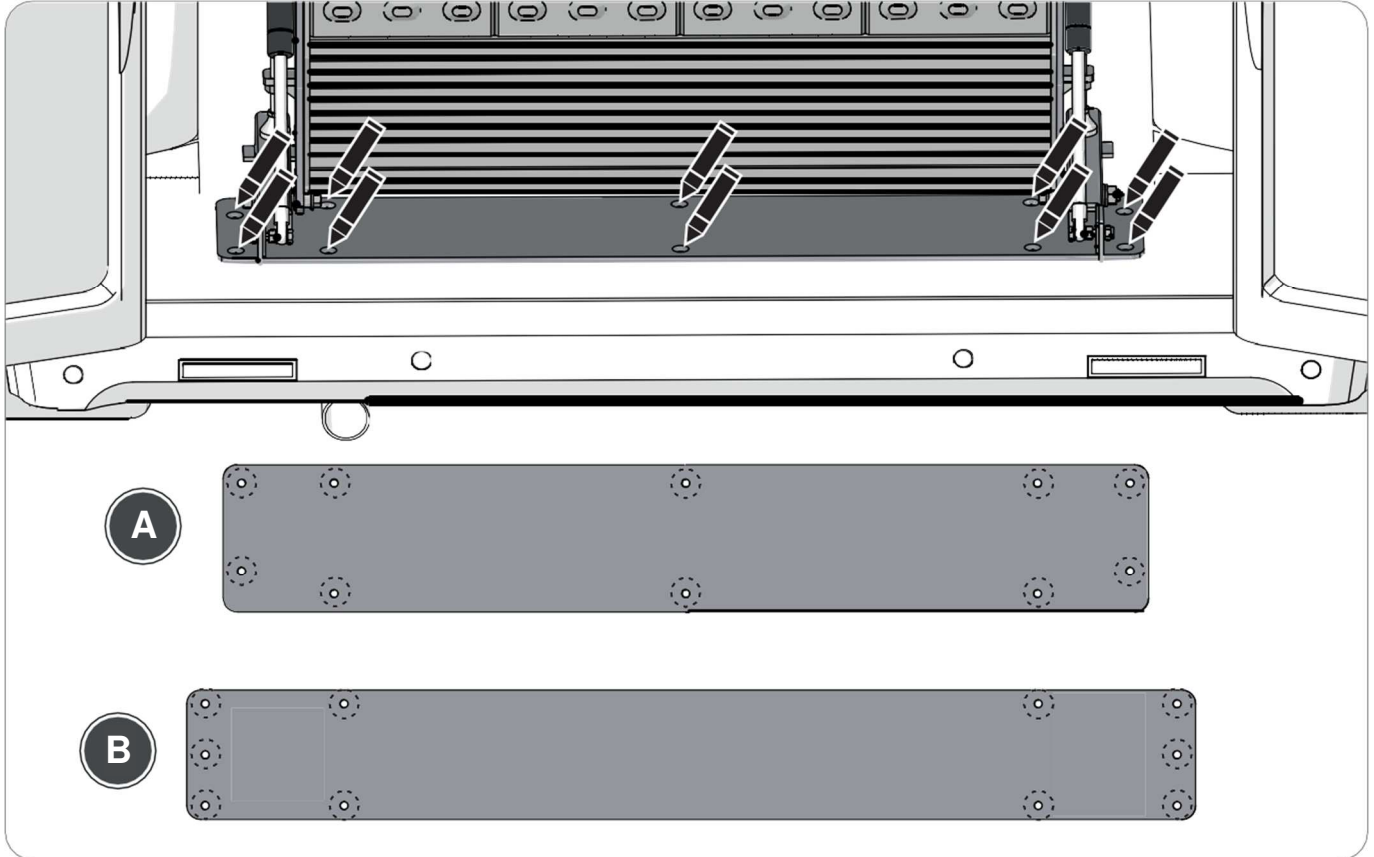

Fig. 2.10

Move the ramp out of the way and drill the holes at the points you marked earlier.

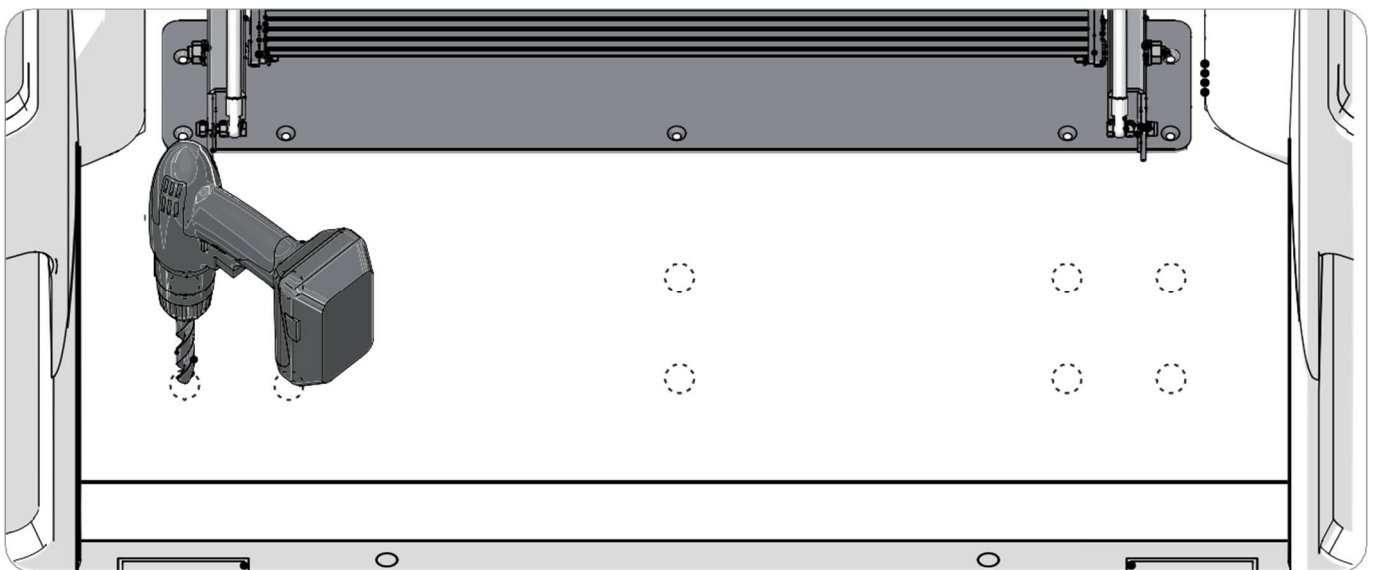

Fig. 2.11

Line up the ramp's baseplate with the holes/contours you marked earlier.

Insert the countersunk screws (1a) M8x100 (No. 10) into the ramp's baseplate.

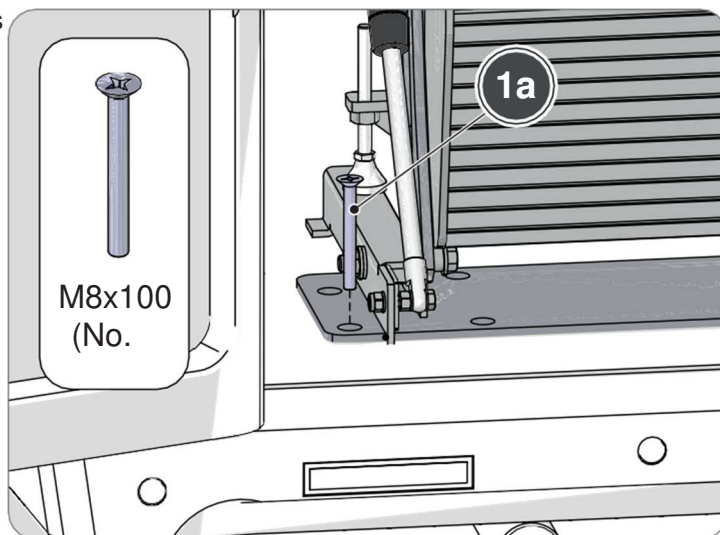

Fig. 2.12

Insert the washers (1b) 8x3x24 and self-locking nuts (1c) M8 into the underside of the van without tightening them completely.

Check over the assembly and then screw down the nuts (1c), torque 23 Nm.

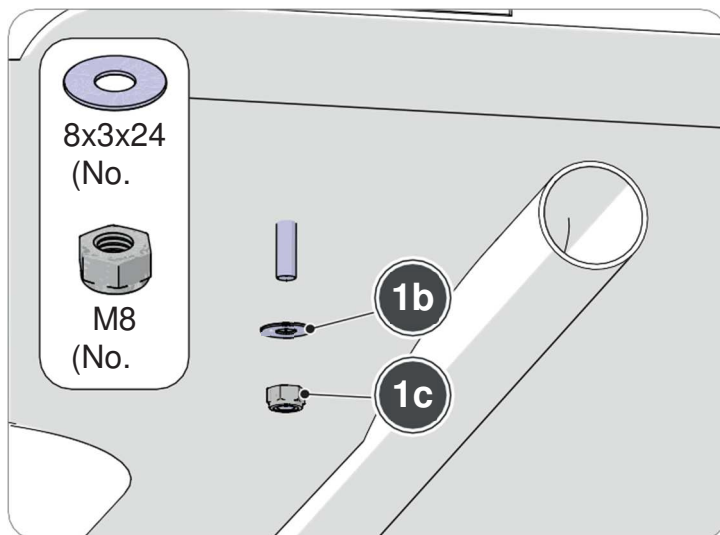

Fig. 2.13

The safety catch (3) must be released before opening the ramp.

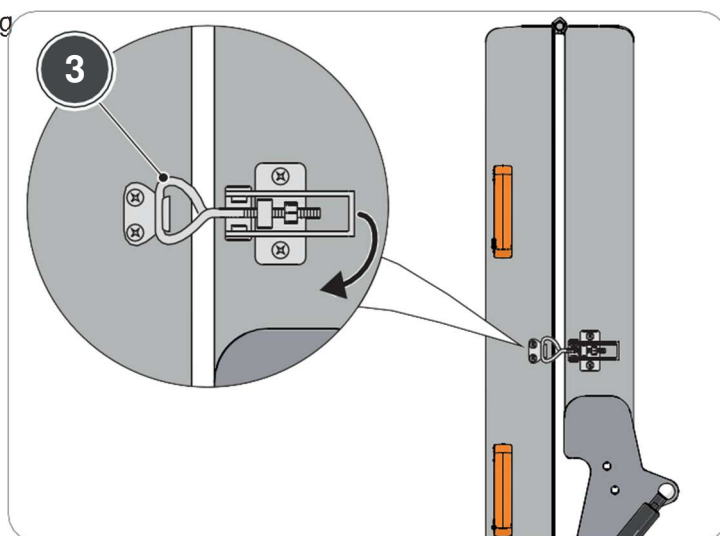

Fig. 2.14

Open the ramp using the handles on the sides. Check the ramp is working properly.

On some models (or on request), the ramp has two brackets with screw-on feet at the centre near the hinge. These brackets have a rocker mechanism so that they can be positioned perpendicular to the ground when the ramp is opened. As their height is adjustable, they can adapt to suit any requirement.



NOTE: The ramp's capacity is indicated on the name plate (Fig.1.2).

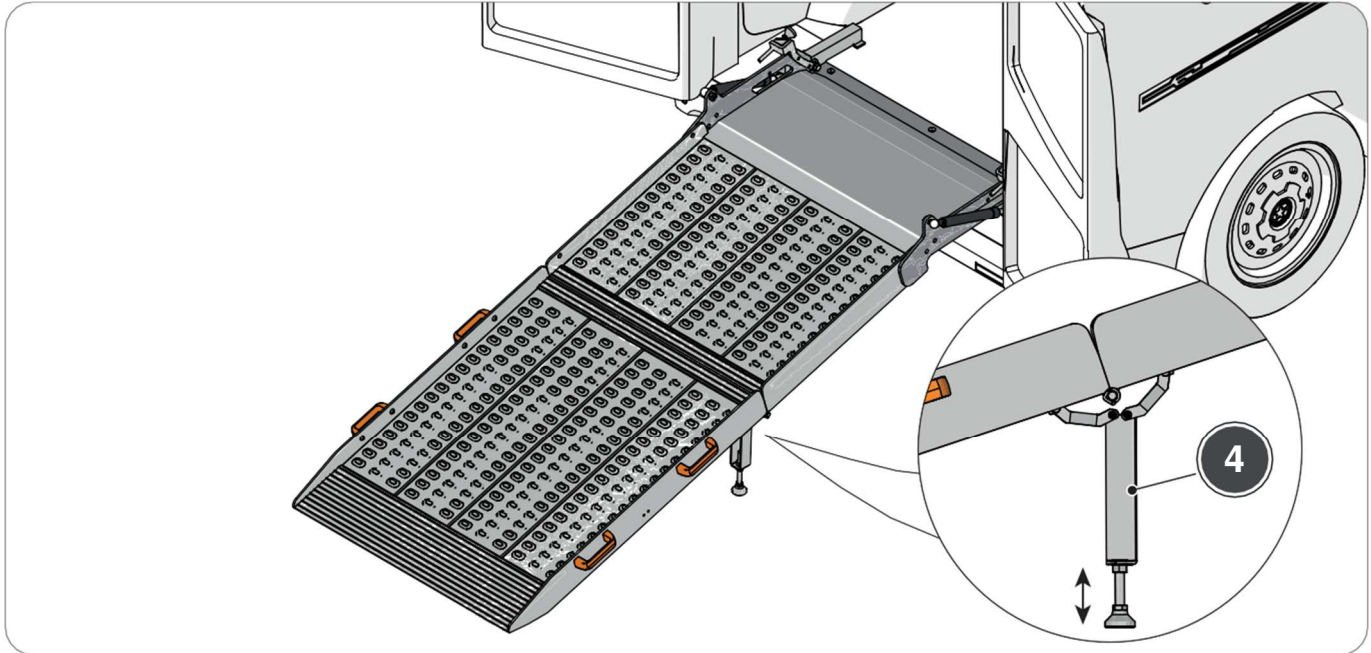

Fig. 2.15



ATTENTION: After use, close the ramp and replace the safety catch (3). Attach the supplied safety straps (2) as illustrated.

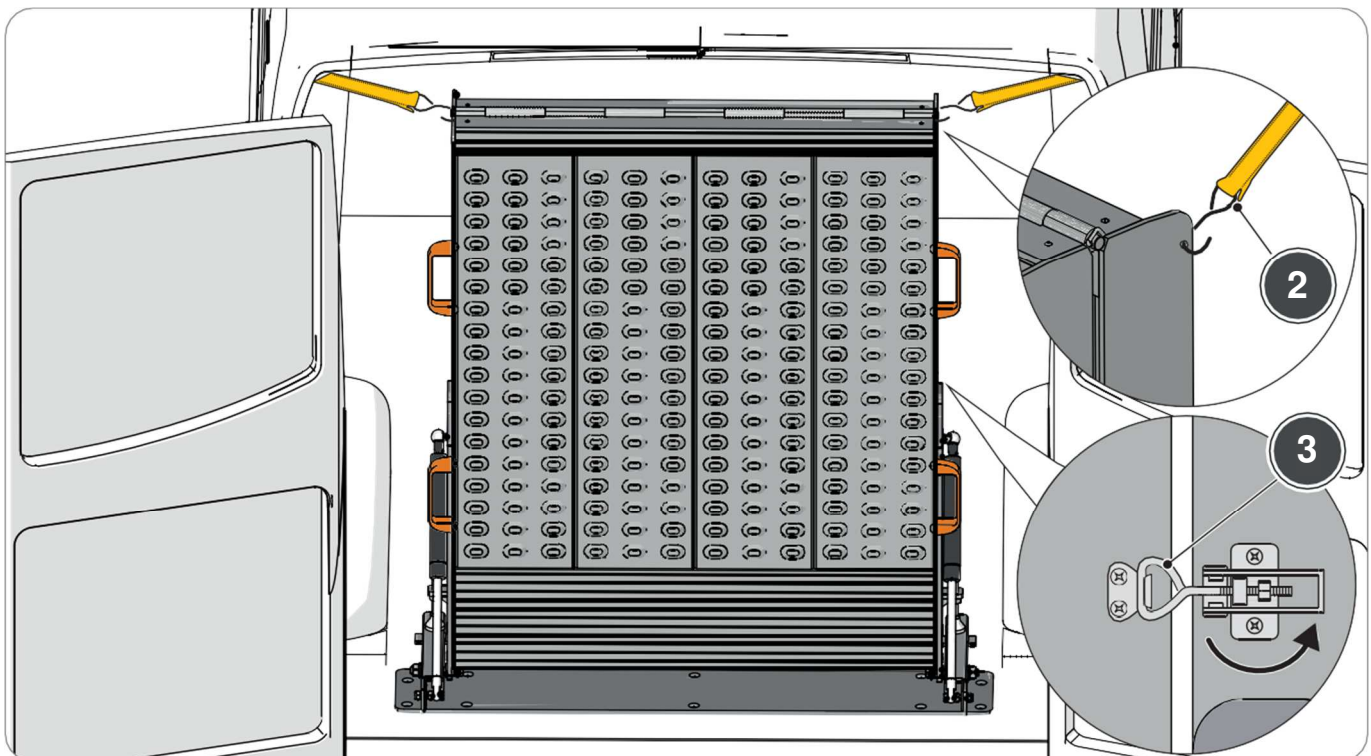

Fig. 2.16

2.1 Fitting the quick-release couplings (optional)

The main purpose of the quick-release couplings (Fig.2.2) is so that the ramp can be removed at any time. The quick-release couplings can be fitted to either the fixed-base ramp or the revolving-base ramp (also as a retro-fit if you need to convert the ramp from a fixed to revolving version).

Insert the two brackets (5) at the sides of the ramp base (already in the correct position, see Fig.2.7), as shown.

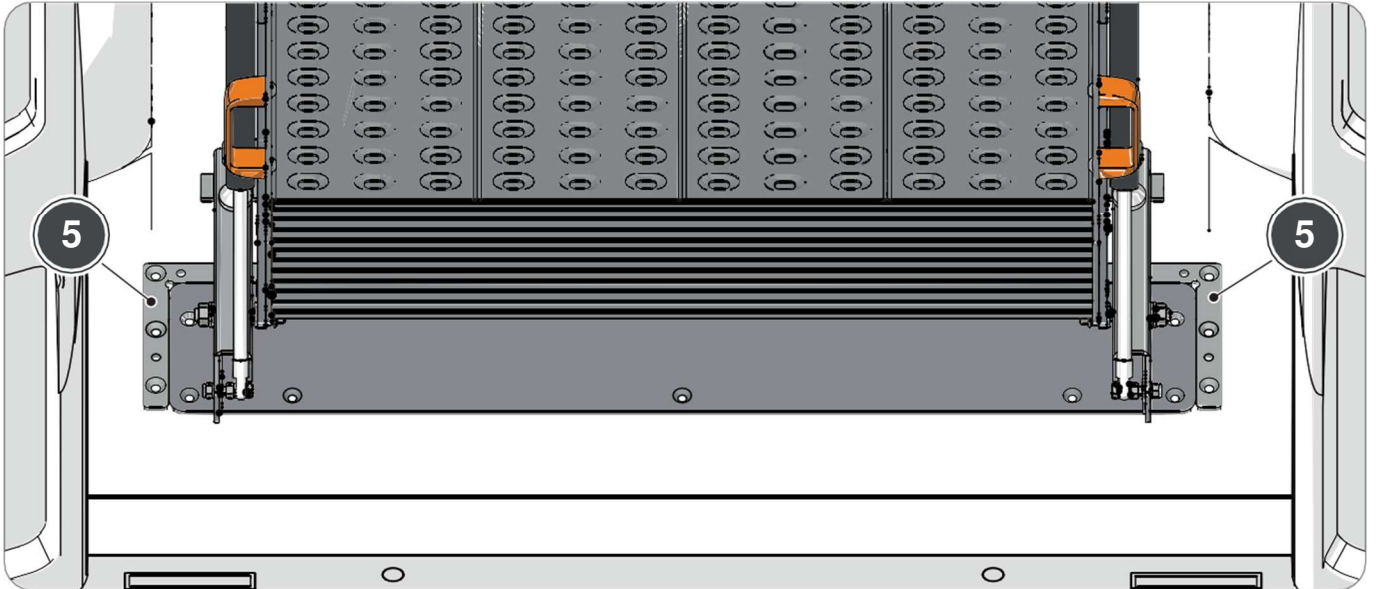

Fig. 2.17

Mark all the holes on both supports using a felt-tip pen.

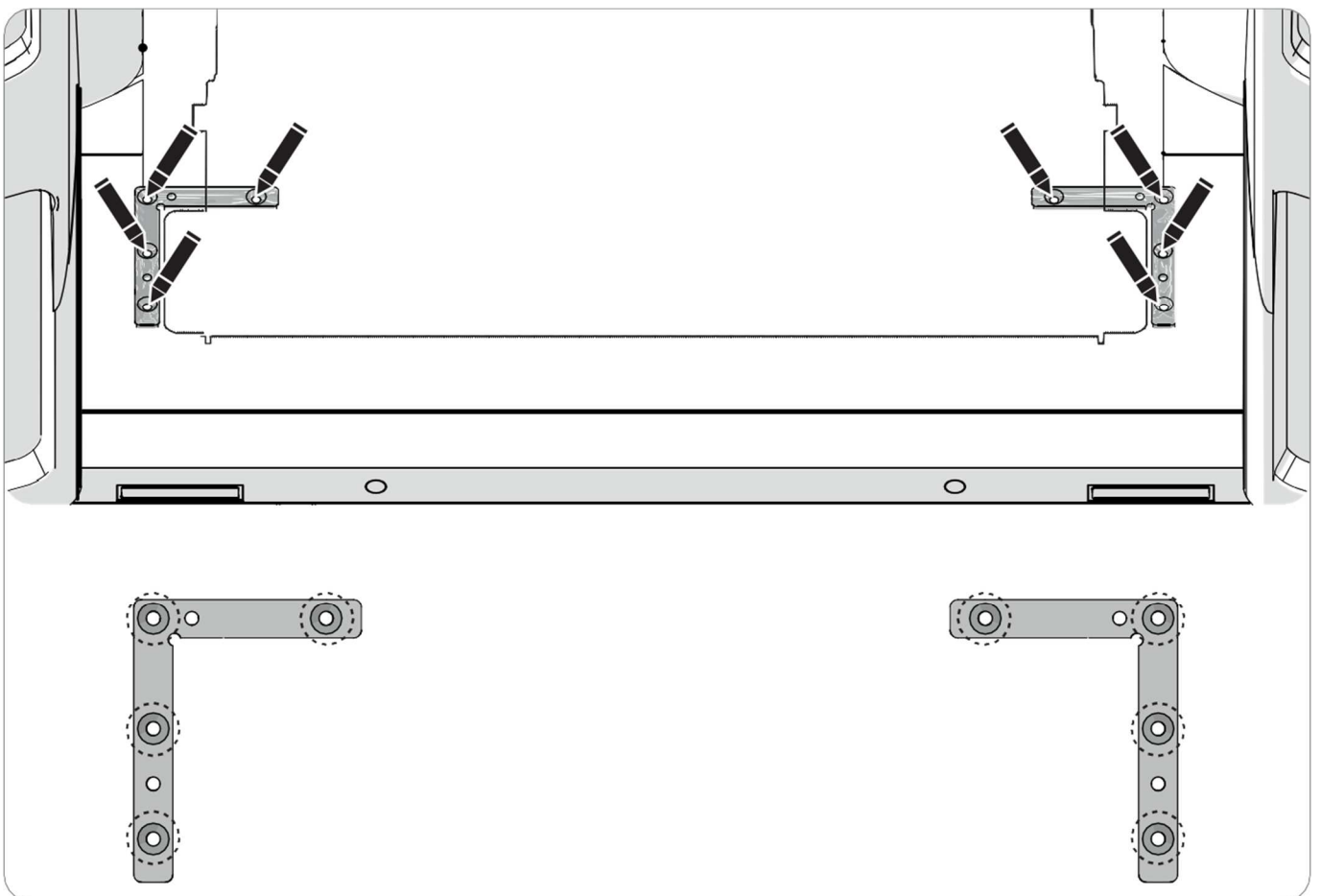

Fig. 2.18

Move the brackets out of the way and drill the holes at the points you marked earlier.

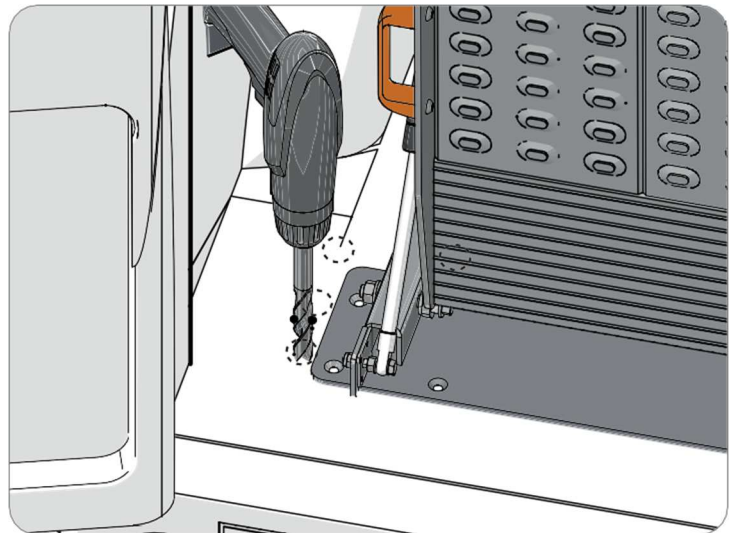

Fig. 2.19

Replace the brackets (5) in the correct positions.

Insert the countersunk screws (1a) M8X100 (No. 8 in total, 4 for both brackets).

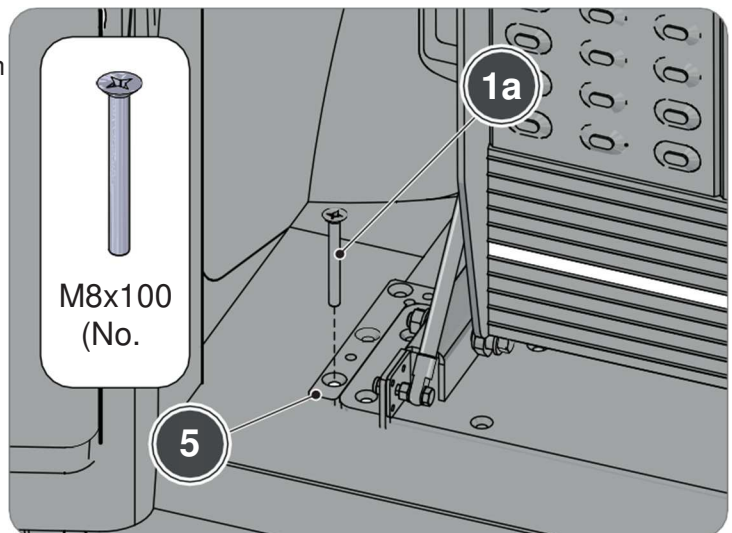

Fig. 2.20

Insert the washers (1b) 8x3x24 and self-locking nuts (1c) M8 into the underside of the van without tightening them completely.

Check over the assembly and then screw down the nuts (1c), torque 23 Nm.

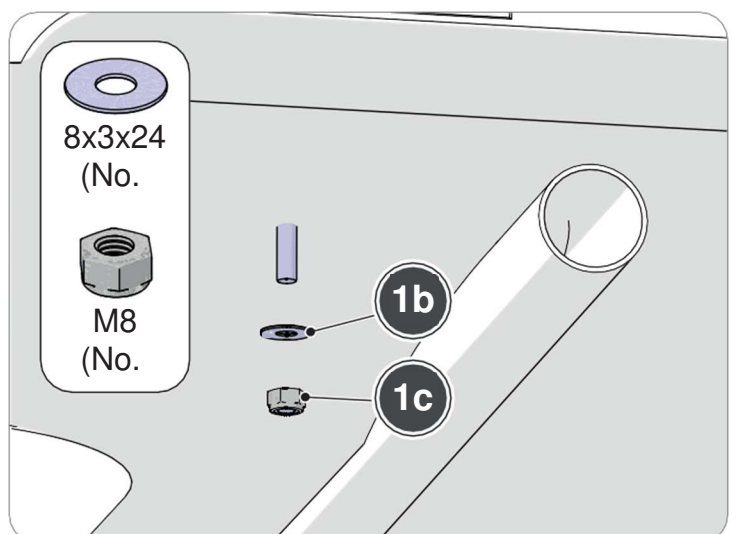

Fig. 2.21

Put the slot fasteners (6) into position on the bracket (5).

Insert and screw the handles (7) onto the bracket (5). If you are unable to turn the handle fully (due to lack of space) press button (7a) so that the handle can turn idle and then be put into position, as required.

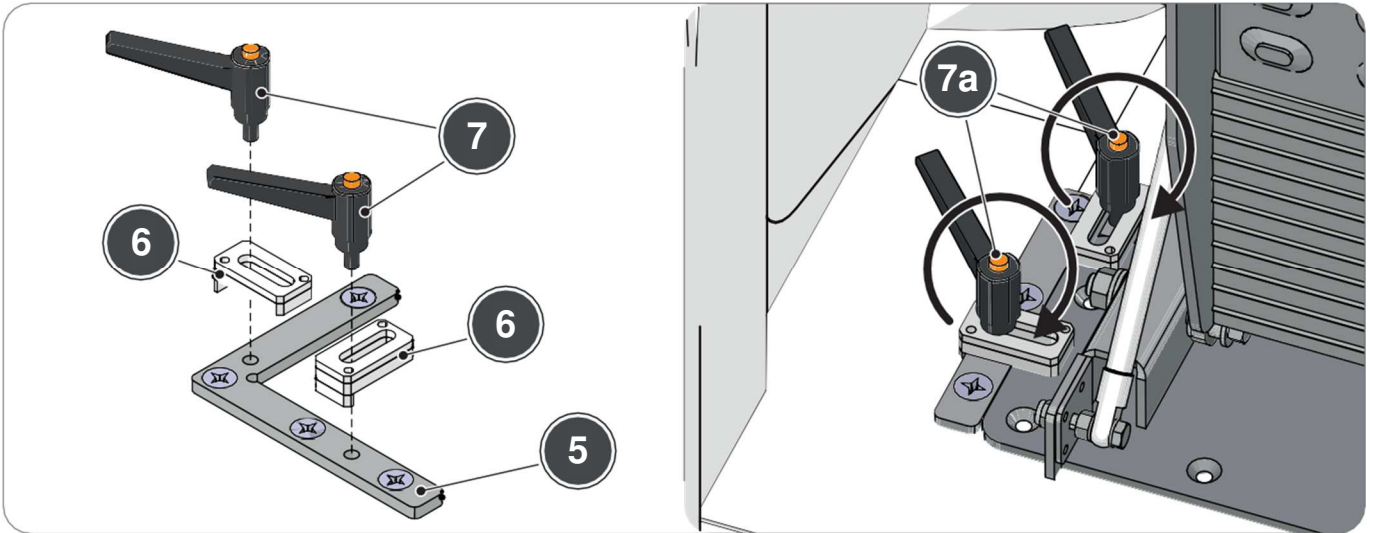

Fig. 2.22

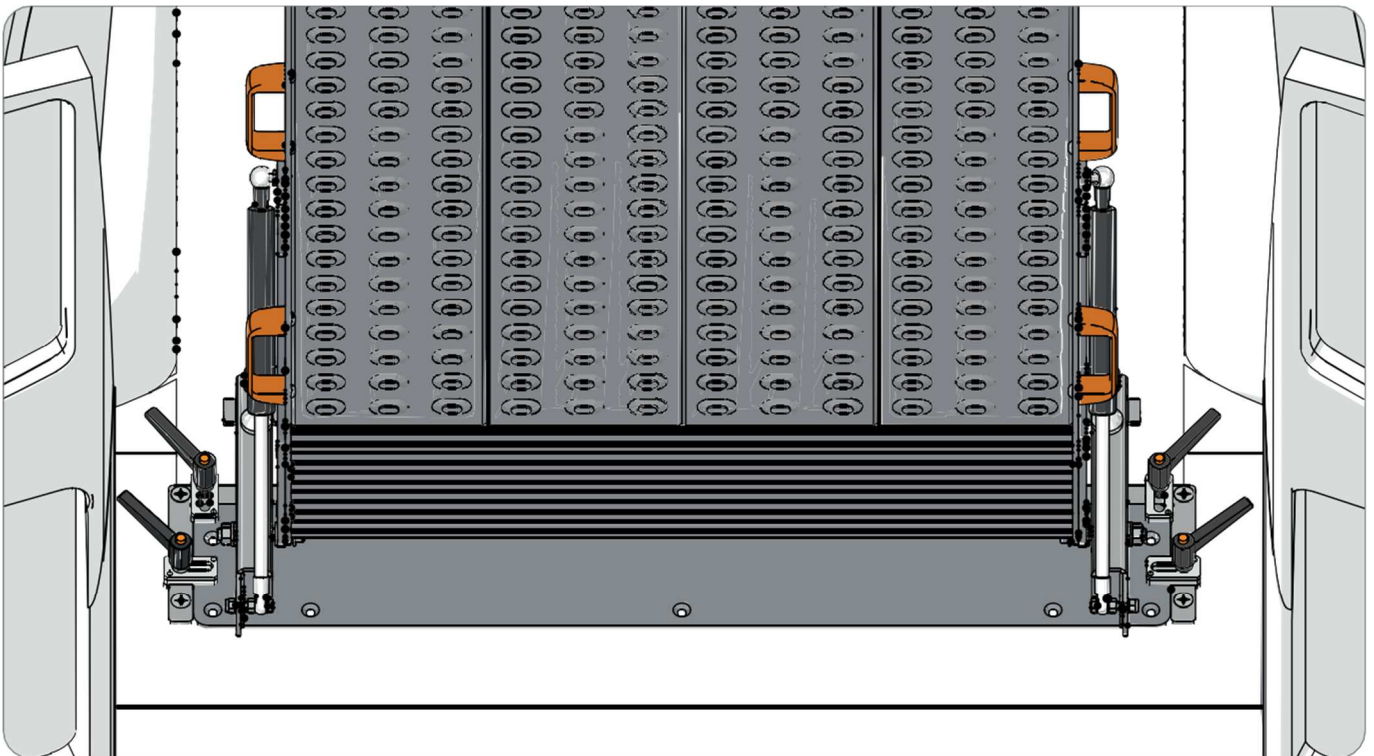

Fig. 2.23



WARNING Tighten the handles (7) and check the ramp's baseplate is securely locked.

To remove the ramp, simply unscrew the handles (7) just enough to release the catches (6) as illustrated.

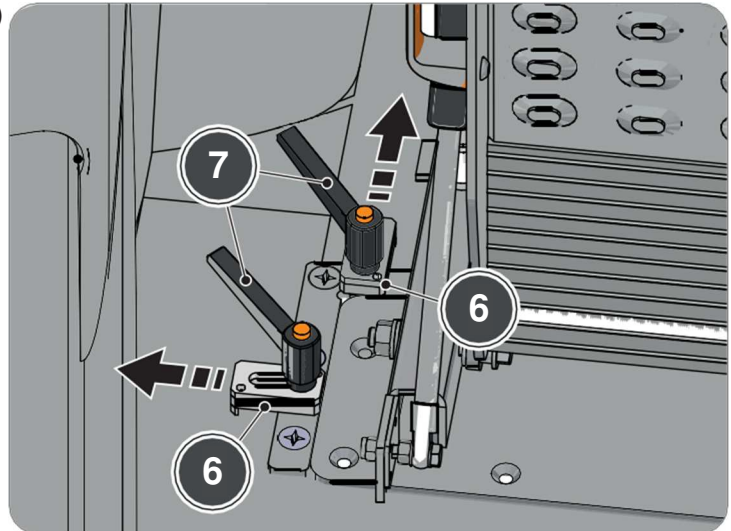

Fig. 2.24

Remove the ramp.



ATTENTION: Two people are required to carry out the following step. Take care: the ramp is very heavy!

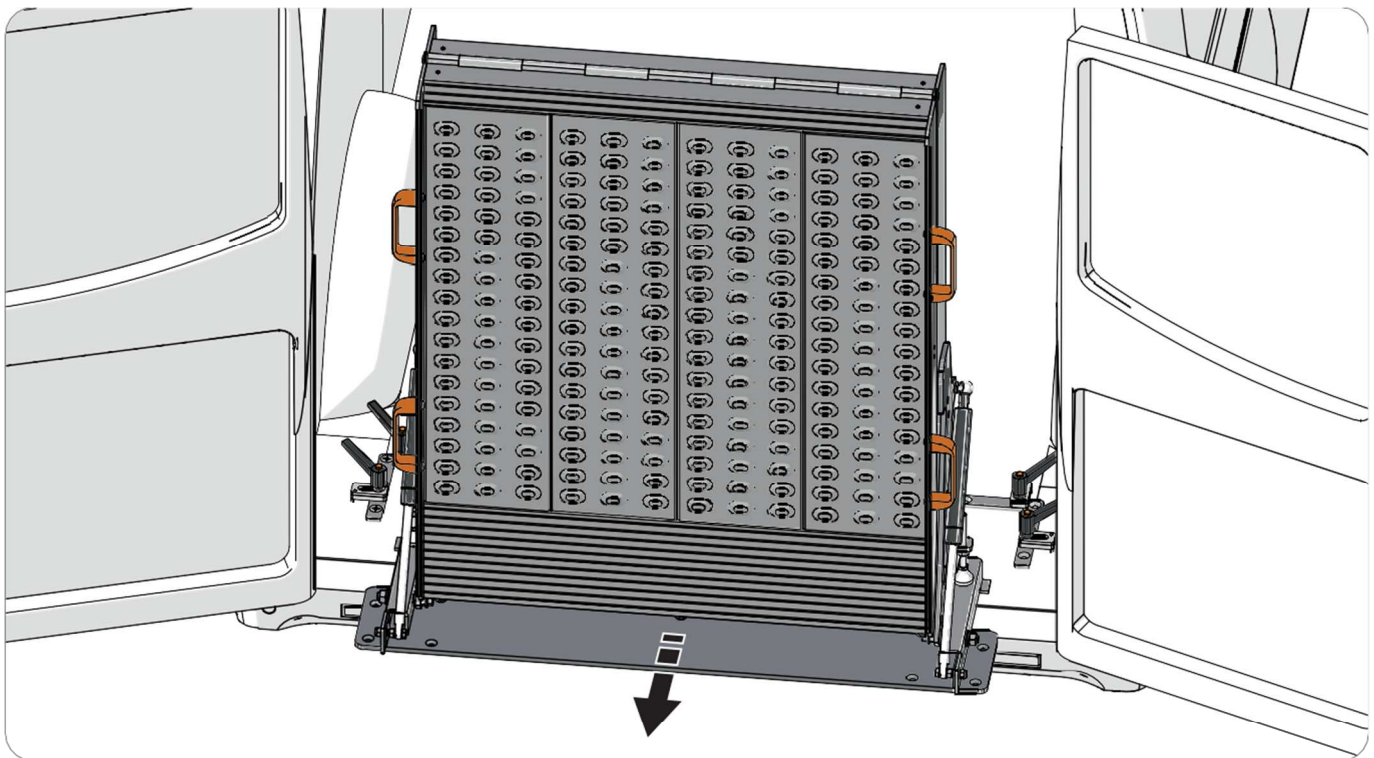

Fig. 2.25



WARNING To replace the ramp, put the ramp's baseplate back into position as shown in (Fig.2.22). Make sure the catches (6) are in contact with the baseplate and tighten the handles (7).

If the quick-release couplings were retrofitted (after the initial installation of the ramp), all screws, washers and nuts used on the ramp's baseplate must be removed.

2.2 The revolving ramp base

To open the revolving base ramp, the safety lock (8) must be pulled to release the catch.



NOTE: The ramp may be fitted with a second safety lock (9).

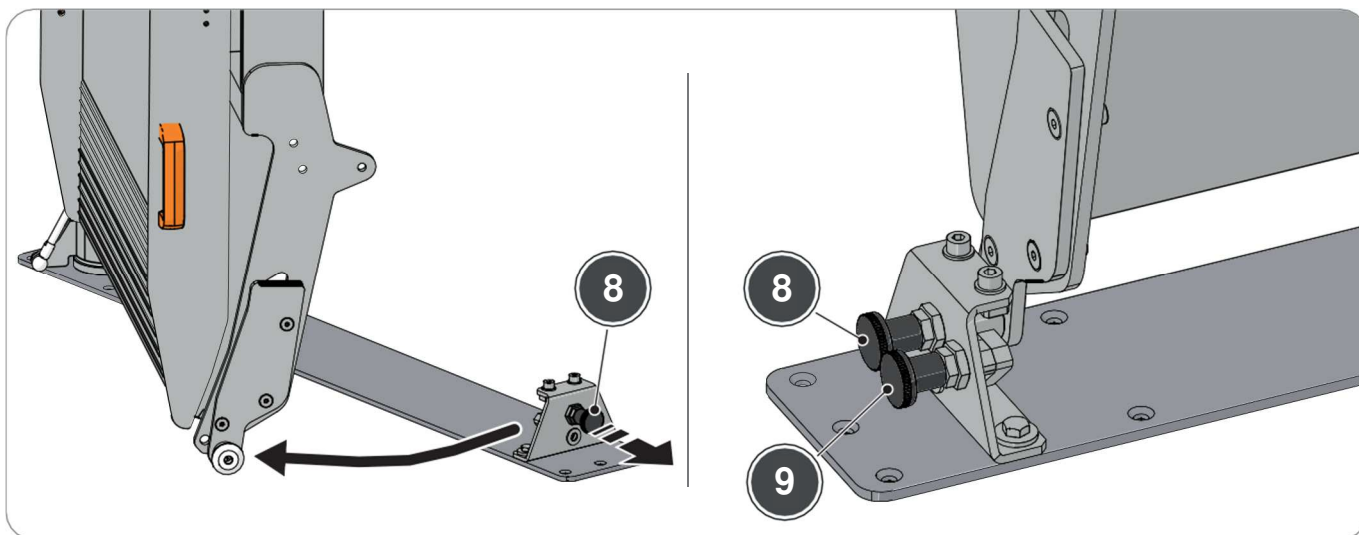

Fig. 2.26

Make sure the ramp can turn (without impediment) both inside and outside.

The revolving base ramp opens exactly the same way as the fixed-base ramp and can be fitted with two support brackets (Fig.2.15).

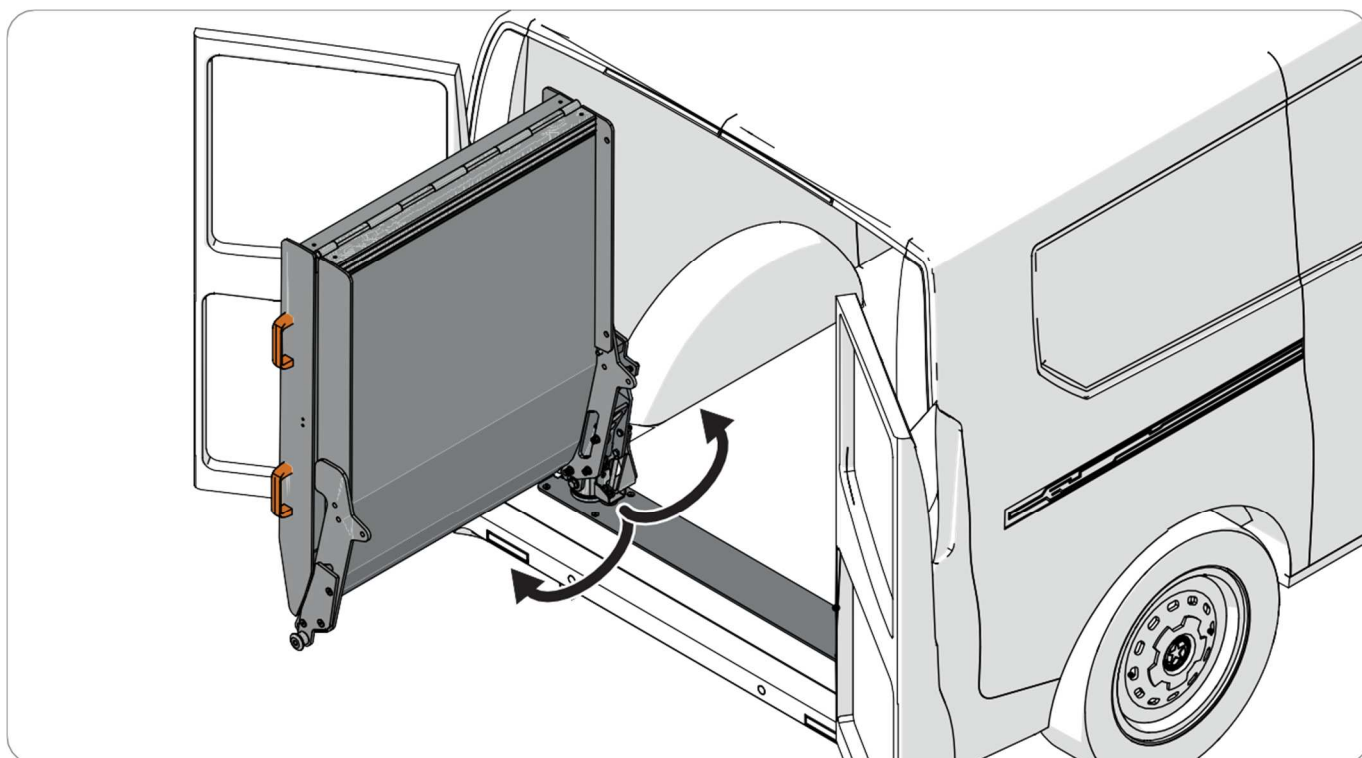

Fig. 2.27



ATTENTION: After use, secure the ramp with the safety locks (8 and 9, if present). Close the ramp and replace the safety catch (3, Fig.2.16).

Attach the supplied safety straps (2) (Fig.2.16).